















## Through Bolts







Technical Specifications







## Through Bolts product overview

	BA-V Plus	BA-F Plus	BA-E Plus
<b>Anchor</b>			
<b>Material</b>	Carbon steel Zinc electroplated	Carbon steel Hot dip galvanized	Stainless steel A4
<b>Applications</b>	Dry indoor conditions, indoor with temporary condensation	Humid indoor use, outdoor inland rural areas only in not safety relevant applications	For indoor, outdoor, industrial use and maritime climate.
<b>Base materials</b>	Cracked concrete Non-cracked concrete	Cracked concrete Non-cracked concrete	Cracked concrete Non-cracked concrete
<b>Thread size*</b>	M8, M10, M12, M16	M8, M10, M12, M16	M8, M10, M12, M16
<b>Tools</b>	Setting tool BA	Setting tool BA	Setting tool BA
<b>Technical data</b>	 F120  C1/C2	 F120	 F120  C1/C2  Rostfrei STAINLESS STEEL
<b>Approvals</b>	 ETA-16/0934  ETA-18/0219	 ETA-16/0934  ETA-18/0219	 ETA-16/0934  ETA-18/0219

**Note:** Diameter M6 for multiple use for non-structural applications in concrete available on demand. BA-E Plus HCR available on request

BA-E Plus HCR	BA-C NC
	
<p>Stainless steel HCR 1.4529 / 1.4565</p>	<p>Carbon steel Zinc electroplated</p>
<p>HCR for extremely corrosive conditions, such as high chlorine concentrations (swimming halls) road tunnels and desulphurization plants</p>	<p>Dry internal conditions</p>
<p>Cracked concrete Non-cracked concrete</p>	<p>Non-Cracked concrete <math>\geq</math> C20/25 "Option 7"</p>
<p>M8, M10, M12, M16</p>	<p>M8, M10, M12, M16</p>
<p>Setting tool BA</p>	<p>Setting tool BA</p>
  	
 <p>ETA-16/0934</p>	 <p>ETA-20/0286</p>

## Approvals / Certifications / Applications

Description of document		Authority/ Laboratory	ID	Additional info
European Technical Assessment		ZAG -National Building and Civil Engineering Institute, Slovenia ETA Danmark A/S	BA Plus: ETA-16/0934 ETA-18/0219  BA-C-NC: ETA-20/0286	EAD 330232-01-0601
Fire resistance		ZAG -National Building and Civil Engineering Institute, Slovenia	ETA-16/0934 ETA-18/0219	EOTA TR 020 / EN 1992-4
Seismic resistance		ZAG -National Building and Civil Engineering Institute, Slovenia	ETA-16/0934 ETA-18/0219	EOTA TR 045 BA-V Plus / BA-E Plus anchor size M8 – M16: C2
EJOT Anchor Fix calculation software		EJOT Software		Free download: <a href="https://www.ejot.com/software-anchorfix">https://www.ejot.com/software-anchorfix</a>

**Additional information concerning all given data in the product data sheet**

- > Load figures include the partial safety factors as per approvals and a partial safety factor on the action of  $\gamma_{F=}$  1.4. Load figures apply for a rebar spacing  $s \geq 15$  cm or alternatively for a rebar spacing  $s \geq 10$  cm in combination with a rebar diameter of  $d_s \leq 10$  mm.
- > If spacings or edge distances become smaller than the characteristic figures ( $s_{cr,N} / c_{cr,N}$ ) a calculation as per EOTA TR 055 needs to be carried out. For more details, see ETAs.
- > Concrete is considered non-cracked when the value of tension within the concrete is  $\sigma_L + \sigma_R \leq 0$ . In the absence of detailed verification  $\sigma_R = 3$  N/mm<sup>2</sup> can be assumed ( $\sigma_L$  equals the tension within the concrete as a result of external loads, forces on anchor included;  $\sigma_R$  equals the tension coming from shrinkage or creep of the concrete, as well as displacements of supports or temperature variations).
- > Shear load figures apply for an anchor without influence of a concrete edge. For shear loads close to an edge ( $c \leq 10 \times h_{ef}$ ), concrete edge failure has to be checked as per EOTA TR 055.

## Static and quasi-static loads

### Characteristic resistances

Anchor size		M8 x 50 <sup>1</sup>	M8 [Opt. 7]	M8	M10	M10 [Opt. 7]	M12	M16				
Effective anchorage depth $h_{ef}$		[mm]	23	43	35	48	40	60	50	50	70	85
<b>Non-cracked concrete</b>												
Tensile $N_{Rk}$	BA-V Plus / BA-F Plus	[kN]	-	-	8.0	11.0	12.0	19.0	-	17.4	25.0	36.0
	BA-E Plus / BA-E Plus HCR	[kN]	-	-	8.0	11.0	12.0	19.0	-	17.4	25.0	36.0
	BA-C NC	[kN]	4.3	11.0	-	-	-	-	13.0	-	17.0	22.0
Shear $V_{Rk}$	BA-V Plus / BA-F Plus	[kN]	-	-	12.6*	12.6*	20.4*	20.4*	-	30.0*	30.0*	54.1*
	BA-E Plus / BA-E Plus HCR	[kN]	-	-	15.8*	15.8*	20.4*	20.4*	-	34.4*	34.4*	68.6*
	BA-C NC	[kN]	5.4	7.0*	-	-	-	-	13.0	-	20.0	34.0
<b>Cracked concrete</b>												
Tensile $N_{Rk}$	BA-V Plus / BA-F Plus	[kN]	-	-	5.0	8.5	8.7	12.0	-	12.2	16.0	24.0
	BA-E Plus / BA-E Plus HCR	[kN]	-	-	5.0	8.5	8.7	12.0	-	12.2	16.0	24.0
Shear $V_{Rk}$	BA-V Plus / BA-F Plus	[kN]	-	-	12.6*	12.6*	20.4*	20.4*	-	34.6	30.0*	54.1*
	BA-E Plus / BA-E Plus HCR	[kN]	-	-	15.8*	15.8*	20.4*	20.4*	-	34.6	34.4*	73.1

\*Failure mode = steel; <sup>1</sup>No ETA

### Design resistances

Anchor size		M8 x 50 <sup>1</sup>	M8 [Opt. 7]	M8	M10	M10 [Opt. 7]	M12	M16				
Effective anchorage depth $h_{ef}$		[mm]	23	43	35	48	40	60	50	50	70	85
<b>Non-cracked concrete</b>												
Tensile $N_{Rd}$	BA-V Plus / BA-F Plus	[kN]	-	-	5.3	7.3	8.0	12.7	-	11.6	16.7	24.0
	BA-E Plus / BA-E Plus HCR	[kN]	-	-	5.3	7.3	8.0	12.7	-	11.6	16.7	24.0
	BA-C NC	[kN]	2.4	6.1	-	-	-	-	8.7	-	9.4	14.7
Shear $V_{Rd}$	BA-V Plus / BA-F Plus	[kN]	-	-	10.1*	10.1*	16.3*	16.3*	-	24.0*	24.0*	43.3*
	BA-E Plus / BA-E Plus HCR	[kN]	-	-	12.6*	12.6*	16.3*	16.3*	-	27.5*	27.5*	54.9*
	BA-C NC	[kN]	3.6	5.18*	-	-	-	-	8.68	-	15.82	22.68
<b>Cracked concrete</b>												
Tensile $N_{Rd}$	BA-V Plus / BA-F Plus	[kN]	-	-	3.3	5.7	5.8	8.0	-	8.1	10.7	16.0
	BA-E Plus / BA-E Plus HCR	[kN]	-	-	3.3	5.7	5.8	8.0	-	8.1	10.7	16.0
Shear $V_{Rd}$	BA-V Plus / BA-F Plus	[kN]	-	-	10.1*	10.1*	16.3*	16.3*	-	23.1	24.0*	43.3*
	BA-E Plus / BA-E Plus HCR	[kN]	-	-	10.5	12.6*	16.3*	16.3*	-	23.1	27.5*	48.7

\*Failure mode = steel; <sup>1</sup>No ETA

#### The data of these tables is based on:

- > Concrete C20/25,  $f_{ck,cube} = 25 \text{ N/mm}^2$
- > Installation has been done correctly
- > No influence of edge distances and spacings
- > Respect of minimum base material thickness

## Static and quasi-static loads

### Recommended loads

Anchor size		M8 x 50 <sup>1</sup>	M8 [Opt. 7]	M8	M10	M10 [Opt. 7]	M12	M16				
Effective anchorage depth $h_{ef}$		[mm]	23	43	35	48	40	60	50	50	70	85
<b>Non-cracked concrete</b>												
Tensile $N_{Rec}$	BA-V Plus / BA-F Plus	[kN]	-	-	3.8	5.2	5.7	9.0	-	8.3	11.9	17.1
	BA-E Plus / BA-E Plus HCR	[kN]	-	-	3.8	5.2	5.7	9.0	-	8.3	11.9	17.1
	BA-C-NC	[kN]	1.7	4.4	-	-	-	-	6.2	-	6.7	10.5
Shear $V_{Rec}$	BA-V Plus / BA-F Plus	[kN]	-	-	7.2*	7.2*	11.7*	11.7*	-	17.1*	17.1*	30.9*
	BA-E Plus / BA-E Plus HCR	[kN]	-	-	9.0*	9.0*	11.7*	11.7*	-	19.7*	19.7*	39.2*
	BA-C-NC	[kN]	2.6	3.7*	-	-	-	-	6.2	-	11.3	16.2
<b>Cracked concrete</b>												
Tensile $N_{Rec}$	BA-V Plus / BA-F Plus	[kN]	-	-	2.4	4.0	4.1	5.7	-	5.8	7.6	11.4
	BA-E Plus / BA-E Plus HCR	[kN]	-	-	2.4	4.0	4.1	5.7	-	5.8	7.6	11.4
Shear $V_{Rec}$	BA-V Plus / BA-F Plus	[kN]	-	-	7.2*	7.2*	11.7*	11.7*	-	16.5	17.1*	30.9*
	BA-E Plus / BA-E Plus HCR	[kN]	-	-	7.5	9.0*	11.7*	11.7*	-	16.5	19.7*	34.8

\*Failure mode = steel; <sup>1</sup>No ETA

#### The data of these tables is based on:

- > Concrete C20/25,  $f_{ck,cube} = 25 \text{ N/mm}^2$
- > Installation has been done correctly
- > No influence of edge distances and spacings
- > Respect of minimum base material thickness

## Seismic resistance (only BA Plus)

Design acc. EOTA TR 045: Performance category C2



### Characteristic resistances

Anchor size			M8 (C2)	M10 (C2)	M12 (C2)	M16 (C2)
Effective anchorage depth $h_{ef}$		[mm]	48	60	70	85
<b>Cracked concrete</b>						
Tensile $N_{Rk, seis}$	BA-V Plus	[kN]	1.7	2.7	2.8	10.2
	BA-E Plus	[kN]	3.6	3.2	3.3	11.1
Shear $V_{Rk, seis}$	BA-V Plus	[kN]	4.8*	4.3*	6.9*	15.4*
	BA-E Plus	[kN]	4.2*	4.7*	7.2*	15.4*

### Design resistance

Anchor size			M8 (C2)	M10 (C2)	M12 (C2)	M16 (C2)
Effective anchorage depth $h_{ef}$		[mm]	48	60	70	85
<b>Cracked concrete</b>						
Tensile $N_{Rd, seis}$	BA-V Plus	[kN]	1.1	1.8	1.9	6.8
	BA-E Plus	[kN]	2.4	2.1	2.2	7.4
Shear $V_{Rd, seis}$	BA-V Plus	[kN]	3.8*	3.4*	5.5*	12.3*
	BA-E Plus	[kN]	3.4*	3.8*	5.8*	12.3*

### Recommended loads

Anchor size			M8 (C2)	M10 (C2)	M12 (C2)	M16 (C2)
Effective anchorage depth $h_{ef}$		[mm]	48	60	70	85
<b>Cracked concrete</b>						
Tensile $N_{Rec, seis}$	BA-V Plus	[kN]	0.8	1.3	1.3	4.9
	BA-E Plus	[kN]	1.7	1.5	1.6	5.3
Shear $V_{Rec, seis}$	BA-V Plus	[kN]	2.7*	2.4*	3.9*	8.8*
	BA-E Plus	[kN]	2.4*	2.7*	4.1*	8.8*

$\alpha_{seis}$  and  $\alpha_{gap}$  included as per EOTA TR 045. The values don't consider any filling of the annular gap between the anchor and the fixture

\* Failure mode = steel

#### The data of these tables is based on:

- > Concrete C20/25,  $f_{ck, cube} = 25 \text{ N/mm}^2$
- > Installation has been done correctly
- > No influence of edge distances and spacings
- > Respect of minimum base material thickness

## Fire resistance (only BA Plus)



## Characteristic resistances

Anchor size			M8		M10		M12		M16	
Effective anchorage depth $h_{ef}$		[mm]	35	48	40	60	50	70	85	
<b>R30</b>										
Tensile $N_{Rk,fi}$	BA-V Plus / BA-F Plus	[kN]	1.25	1.31	1.82	2.09	3.05	3.05	5.69	
	BA-E Plus / BA-E Plus HCR	[kN]	1.25	2.13	1.82	3.00	3.18	4.00	6.00	
Shear $V_{Rk,fi}$	BA-V Plus / BA-F Plus	[kN]	1.31	1.31	2.09	2.09	3.05	3.05	5.69	
	BA-E Plus / BA-E Plus HCR	[kN]	2.76	3.92	6.02	6.66	9.03	10.25	19.09	
<b>R60</b>										
Tensile $N_{Rk,fi}$	BA-V Plus / BA-F Plus	[kN]	1.05	1.05	1.66	1.66	2.40	2.40	4.47	
	BA-E Plus / BA-E Plus HCR	[kN]	1.25	2.13	1.82	3.00	3.18	4.00	6.00	
Shear $V_{Rk,fi}$	BA-V Plus / BA-F Plus	[kN]	1.05	1.05	1.66	1.66	2.40	2.40	4.47	
	BA-E Plus / BA-E Plus HCR	[kN]	2.70	2.70	4.59	4.59	7.07	7.07	13.16	
<b>R90</b>										
Tensile $N_{Rk,fi}$	BA-V Plus / BA-F Plus	[kN]	0.80	0.80	1.24	1.24	1.74	1.74	3.25	
	BA-E Plus / BA-E Plus HCR	[kN]	1.25	1.48	1.82	2.52	3.18	3.88	6.00	
Shear $V_{Rk,fi}$	BA-V Plus / BA-F Plus	[kN]	0.80	0.80	1.24	1.24	1.74	1.74	3.25	
	BA-E Plus / BA-E Plus HCR	[kN]	1.48	1.48	2.52	2.52	3.88	3.88	7.23	
<b>R120</b>										
Tensile $N_{Rk,fi}$	BA-V Plus / BA-F Plus	[kN]	0.67	0.67	1.02	1.02	1.41	1.41	2.64	
	BA-E Plus / BA-E Plus HCR	[kN]	0.87	0.87	1.46	1.48	2.29	2.29	4.26	
Shear $V_{Rk,fi}$	BA-V Plus / BA-F Plus	[kN]	0.67	0.67	1.02	1.02	1.41	1.41	2.64	
	BA-E Plus / BA-E Plus HCR	[kN]	0.87	0.87	1.48	1.48	2.29	2.29	4.26	

## The data of these tables is based on:

- > In the absence of other national regulations the partial safety factor or resistance under fire exposure  $\gamma_{M,fi} = 1,0$  is recommended
- > Concrete C20/25,  $f_{ck,cube} = 25 \text{ N/mm}^2$
- > Installation has been done correctly
- > No influence of edge distances and spacings
- > Respect of minimum base material thickness



## Fire resistance (only BA Plus)



## Recommended loads

Anchor size			M8	M10	M12	M16			
Effective anchorage depth $h_{ef}$		[mm]	35	48	40	60	50	70	85
<b>R30</b>									
Tensile $N_{Rec, fi}$	BA-V Plus / BA-F Plus	[kN]	1.25	1.31	1.82	2.09	3.05	3.05	5.69
	BA-E Plus / BA-E Plus HCR	[kN]	1.25	2.13	1.82	3.00	3.18	4.00	6.00
Shear $V_{Rec, fi}$	BA-V Plus / BA-F Plus	[kN]	1.31	1.31	2.09	2.09	3.05	3.05	5.69
	BA-E Plus / BA-E Plus HCR	[kN]	2.76	3.92	6.02	6.66	9.03	10.25	19.09
<b>R60</b>									
Tensile $N_{Rec, fi}$	BA-V Plus / BA-F Plus	[kN]	1.05	1.05	1.66	1.66	2.40	2.40	4.47
	BA-E Plus / BA-E Plus HCR	[kN]	1.25	2.13	1.82	3.00	3.18	4.00	6.00
Shear $V_{Rec, fi}$	BA-V Plus / BA-F Plus	[kN]	1.05	1.05	1.66	1.66	2.40	2.40	4.47
	BA-E Plus / BA-E Plus HCR	[kN]	2.70	2.70	4.59	4.59	7.07	7.07	13.16
<b>R90</b>									
Tensile $N_{Rec, fi}$	BA-V Plus / BA-F Plus	[kN]	0.80	0.80	1.24	1.24	1.74	1.74	3.25
	BA-E Plus / BA-E Plus HCR	[kN]	1.25	1.48	1.82	2.52	3.18	3.88	6.00
Shear $V_{Rec, fi}$	BA-V Plus / BA-F Plus	[kN]	0.80	0.80	1.24	1.24	1.74	1.74	3.25
	BA-E Plus / BA-E Plus HCR	[kN]	1.48	1.48	2.52	2.52	3.88	3.88	7.23
<b>R120</b>									
Tensile $N_{Rec, fi}$	BA-V Plus / BA-F Plus	[kN]	0.67	0.67	1.02	1.02	1.41	1.41	2.64
	BA-E Plus / BA-E Plus HCR	[kN]	0.87	0.87	1.46	1.48	2.29	2.29	4.26
Shear $V_{Rec, fi}$	BA-V Plus / BA-F Plus	[kN]	0.67	0.67	1.02	1.02	1.41	1.41	2.64
	BA-E Plus / BA-E Plus HCR	[kN]	0.87	0.87	1.48	1.48	2.29	2.29	4.26

## The data of these tables is based on:

- > In the absence of other national regulations the partial safety factor or resistance under fire exposure  $\gamma_{M, fi} = 1,0$  is recommended
- > Concrete C20/25,  $f_{ck, cube} = 25 \text{ N/mm}^2$
- > Installation has been done correctly
- > No influence of edge distances and spacings
- > Respect of minimum base material thickness

## Material and dimensions

### BA Plus Anchor dimensions

Anchor size			M8	M10	M12	M16
Total length	L	[mm]	57 – 420	62 – 420	78 – 420	118 – 420
Sleeve length	L <sub>s</sub>	[mm]	14.8	17.9	19.1	26.0
Bolt body	d <sub>nom</sub>	[mm]	8	10	12	16
Hexagonal nut	SW	[mm]	13	17	19	24
	m		≥ 6.5	≥ 8.0	≥ 10.0	≥ 13.0

### BA-C NC Anchor dimensions

Anchor size			M8	M10	M12	M16
Total length	L	[mm]	50 – 135	85 – 215	110 – 320	135 – 320
Sleeve length	L <sub>s</sub>	[mm]	14.4	16.5	19.0	23.0
Bolt body	d <sub>nom</sub>	[mm]	8.0	10.0	12.0	16.0
Hexagonal nut	SW	[mm]	13.0	17.0	19.0	24.0

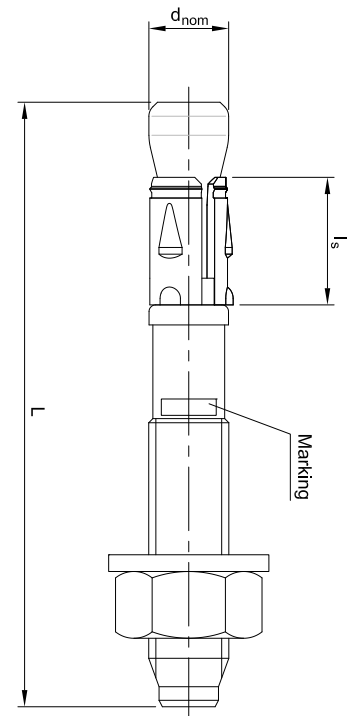

### Mechanical properties

Specifications		Anchor / size		M8	M10	M12	M16
Nominal tensile strength	f <sub>uk, thread</sub>	BA-V Plus / BA-F Plus	[N/mm <sup>2</sup> ]	700	690	690	660
		BA-E Plus / BA-E Plus HCR	[N/mm <sup>2</sup> ]	670	690	690	645
		BA-C NC	[N/mm <sup>2</sup> ]	≥ 550	≥ 670	≥ 630	≥ 600
Char. bending resistance	M <sup>0</sup> <sub>Rk,s</sub>	BA-V Plus / BA-F Plus	[Nm]	26.3	51	90	219.8
		BA-E Plus / BA-E Plus HCR	[Nm]	25.1	51	90	214.8
		BA-C NC	[Nm]	12.0	25.6	45.1	104.4
Design bending resistance	M <sub>Rd,s</sub>	BA-V Plus / BA-F Plus	[kN]	21.0	40.8	72.0	175.8
		BA-E Plus / BA-E Plus HCR	[kN]	20.1	40.8	72.0	171.8
		BA-C NC	[kN]	10.0	17.1	35.8	69.6
Recommended bending resistance	M <sub>Rec</sub>	BA-V Plus / BA-F Plus	[kN]	15.0	29.1	51.4	125.6
		BA-E Plus / BA-E Plus HCR	[kN]	14.3	29.1	51.4	122.7
		BA-C NC	[kN]	6.4	12.2	25.6	49.7

### Material quality

Part of anchor	Anchor	Material
Bolt	BA-V Plus / BA-C NC	Carbon steel, zinc electroplated
	BA-F Plus	Carbon steel, hot dip galvanized
	BA-E Plus	Stainless steel A4
	BA-E Plus HCR	Stainless steel HCR 1.4529 / 1.4565

## Installation instructions

### Installation equipments

Specification	M8	M10	M12	M16
	720 – 1200 U/min / 1.8 – 3.3 J			
Rotary hammer (reccomendation)				360 – 550 r.p.m 4.9 – 11.5 J
Setting tool (optional)	BA-V 6-10 SDS+		BA-V 12-20 SDS+	
Drill bit	SDS+ 2-cut/4-cut 8 mm – 16 mm			
Additional tools	brush, air pump/compressor, hammer, torque wrench			

### Installation data

Parameters and anchors sizes		M8 x 50 <sup>1</sup>	M8	M10	M12	M16				
Drill hole diameter $d_0$	BA-Plus	$d_0$ [mm]	-	8	10	12	16			
	BA-C NC		8							
Cutting diameter at the upper tolerance limit (max. diam. bit)	BA-Plus	$d_{cut, max} \leq$ [mm]	-	8.45	10.45	12.50	16.50			
	BA-C NC		8.45							
Depth of drilled hole to deepest point	BA-Plus	$h_1 \geq$ [mm]	-	47	60	55	75	70	90	110
	BA-C NC		38	63	69	92	109			
Effective anchorage depth	BA-Plus	$h_{ef}$ [mm]	-	35	48	40	60	50	70	85
	BA-C NC		23	43	50	70	85			
Nominal anchorage depth	BA-Plus	$h_{nom}$ [mm]	-	40	53	48	68	61	81	97
Diameter of clearance hole in the fixture	BA-Plus	$d_f \geq$ [mm]	-	9	12	14	18			
	BA-C NC		9							
Width across flats	BA-Plus	SW [mm]	-	13	17	19	24			
	BA-C NC		13							
Required torque	BA-V Plus / BA-F Plus		-	15	30	60	110			
	BA-E Plus / BA-E Plus HCR		$T_{inst}$ [Nm]	-	20	45	60	110		
	BA-C NC			13	15	30	50	90		

<sup>1</sup>No ETA

### Installation methods

Through installation

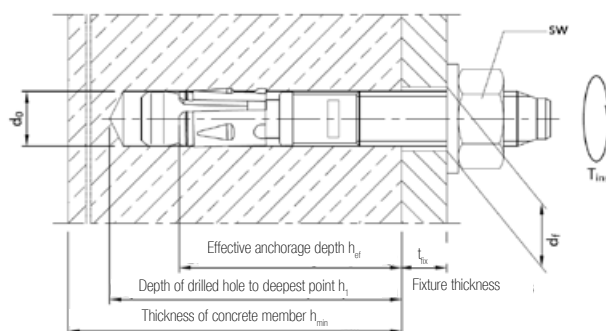

Distance installation

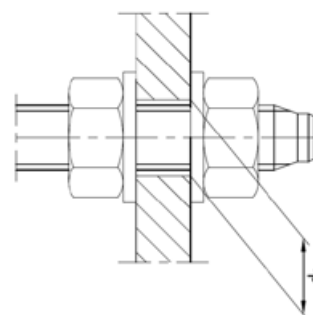

## Installation parameters

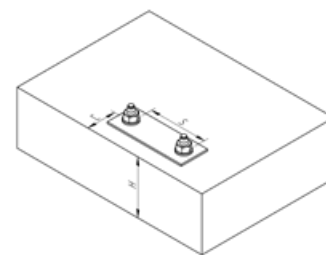

### BA Plus Range

Minimum thickness of concrete member, spacing and edge distance

Cracked and non-cracked concrete			M8	M10	M12	M16			
Effective anchorage depth	$h_{ef}$	[mm]	35	48	40	60	50	70	85
Minimum thickness of base material	$h_{min}$	[mm]	80	100	100	120	100	140	170
	$h_{min-red}$	[mm]	-	80	-	100	-	-	-
Minimum spacing for $h_{min}$	$s_{min}$	[mm]	55	35	50	40	55	60	65
	$c \geq$	[mm]	75	50	95	60	110	70	95
Minimum edge distance for $h_{min}$	$c_{min}$	[mm]	40	40	50	50	60	55	65
	$s \geq$	[mm]	140	55	190	100	215	110	150
Minimum spacing for $h_{min-red}$	$s_{min}$	[mm]	-	35	-	40	-	-	-
	$c \geq$	[mm]	-	55	-	100	-	-	-
Minimum edge distance for $h_{min}$	$c_{min}$	[mm]	-	40	-	60	-	-	-
	$S \geq$	[mm]	-	60	-	90	-	-	-
Critical spacing for splitting failure and concrete cone failure (in case characteristic loading affects)	$s_{cr,sp}$	[mm]	170	192	160	240	200	280	340
	$s_{cr,N}$	[mm]	106	144	120	180	150	210	254
Critical edge distance for splitting failure and concrete cone failure (in case characteristic loading affects)	$c_{cr,sp}$	[mm]	85	96	80	120	100	140	170
	$c_{cr,N}$	[mm]	53	72	60	90	75	105	127

### BA-C NC

Minimum thickness of concrete member, spacing and edge distance

Non-cracked concrete (Option 7)			M8 x 50 <sup>1</sup>	M8	M10	M12	M16
Effective anchorage depth	$h_{ef}$	[mm]	23	43	50	70	85
Minimum thickness of base material	$h_{min}$	[mm]	100	100	120	150	160
Minimum spacing for $h_{min}$	$s_{min}$	[mm]	90	50	100	120	140
Minimum edge distance for $h_{min}$	$c_{min}$	[mm]	50	50	90	100	125

<sup>1</sup>No ETA

## Setting instructions

### Installation

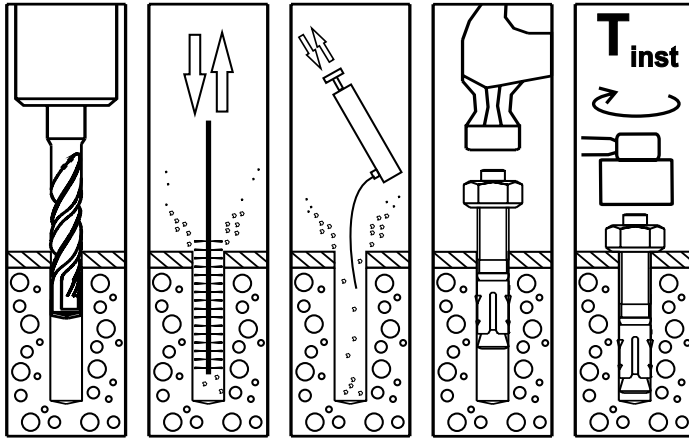

1. Drill a hole according to the product data.
- 2.-3. Clean the hole using a metal brush and a blow-out pump.
4. Install anchor with a hammer or a setting tool.
5. Tighten the anchor to the specified installation torque.

## Accessories

### Setting tool BA

Hammering tool to make through bolt installation quicker and smoother

- > Original EJOT through bolts setting tool with designed head that does not damage the head of the anchor and keep the head from slipping.
- > Besides ensuring most efficient and safe through bolt installation in general, the setting tool also significantly saves time and energy in serial installation.
- > Compatible with all SDS+ chuck machines.



## Delivery program

Thread size	Type	t <sub>fix</sub>	Length	BA-V Plus	BA-F Plus	BA-E Plus	BA-E Plus HCR	BA-C-NC
				Zinc	Hot dip	Stainless steel A4	HCR	Zinc
M8	M8/5/-	5	57	•	•	•	•	-
	M8/23/10	23/10	75	•	•	•	•	•
	M8/43/30	43/30	95	•	•	•	•	•
	M8/63/50	63/50	115	•	•	•	•	•
	M8/98/85	98/85	150	•	•	•	•	-
M10	M10/10/-	10	72	•	•	•	•	-
	M10/10	10	85	-	-	-	-	•
	M10/30/10	30/10	92	•	•	•	•	-
	M10/20	20	95	-	-	-	-	•
	M10/40/20	40/20	102	•	•	•	•	-
	M10/30	30	105	-	-	-	-	•
	M10/50/30	50/30	112	•	•	•	•	-
	M10/50	50	125	-	-	-	-	•
	M10/70/50	70/50	132	•	•	•	•	-
M10/100/80	100/80	162	•	•	•	•	-	
M12	M12/10/-	10	88	•	•	•	•	-
	M12/25/5	25/5	103	•	•	•	•	-
	M12/10	10	110	-	-	-	-	•
	M12/40/20	40/20	118	•	•	•	•	-
	M12/20	20	120	-	-	-	-	•
	M12/30	30	130	-	-	-	-	•
	M12/70/50	70/50	148	•	•	•	•	-
	M12/50	50	150	-	-	-	-	•
	M12/85/65	85/65	163	•	•	•	•	-
M12/100/80	100/80	178	•	•	•	•	-	
M16	M16/5	5	123	•	•	•	•	-
	M16/10	10	135	-	-	-	-	•
	M16/20	20	138	•	•	•	•	-
	M16/20	20	145	-	-	-	-	•
	M16/50	50	168	•	•	•	•	-
	M16/50	50	175	-	-	-	-	•
	M16/60	60	178	•	•	•	•	-

• On request

**Note:** Diameter M6 for multiple use for non-structural applications in concrete available on demand.



## Engineering Service

### EJOT® Anchor Fix 2.0 – anchor dimensioning made easy

With the brand new ANCHOR FIX version 2.0, the free dimensioning software for anchoring, EJOT is offering a very helpful tool for the static dimensioning of anchoring in your projects. Specially developed for structural engineers, specifiers, engineers and technicians, the software can also be used as a handy guide in the pre-planning phase.

With EJOT ANCHOR FIX, the limits of the load-carrying capacity of EJOT anchoring products such as through bolts and concrete screws in concrete substrates can be determined.. Another new feature is the possibility of dimensioning nylon and chemical anchors in concrete and masonry. EJOT CROSSFIX® has also now been fully integrated. In addition, with the new software version, a design for fire and seismic load cases is possible. ANCHOR FIX still allows you to directly input data from site extraction tests and their evaluation in accordance with regulations. The targeted selection of the calculation methods for single vs. multiple fastening of various products offers the user application safety.

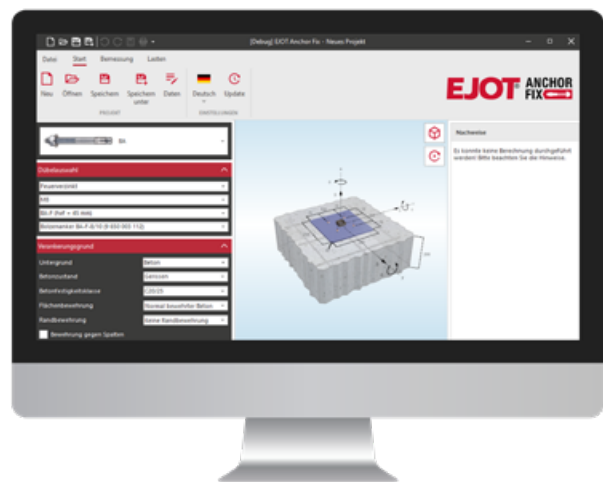

Planning reliability on the part of the user is achieved by the output of individual quantity requirements for chemical anchors and this also has variable setting levels. All additional documents such as approvals and product data sheets can be easily accessed, directly via the software.

Try it out – free of charge ...

EJOT ANCHOR FIX can be downloaded here:

**[www.ejot.com/software-anchifix](http://www.ejot.com/software-anchifix)**



**EJOT SE & Co. KG**

**Market Unit Construction**

In der Stockwiese 35

57334 Bad Laasphe · Germany

T +49 2752 908-0

F +49 2752 908-731

[construction@ejot.com](mailto:construction@ejot.com)

[www.ejot.com/construction](http://www.ejot.com/construction)