

Leistungserklärung



Nr.: 1 - 002 - 210421 - 2021

1.) Eindeutiger Kenncode des Produkttyps:
EJOT Befestigungsschrauben EJOFAST JF6

2.) Verwendungszweck:
Befestigungsschrauben für Bauteile und Bleche aus Metall

3.) Hersteller:
EJOT Baubefestigungen GmbH, In der Stockwiese 35, 57334 Bad Laasphe

4.) System zur Bewertung und Überprüfung der Leistungsbeständigkeit:
System 2+

5.) Europäisches Bewertungsdokument: **EAD 330046-01-0602**
Europäisch Technische Bewertung: **ETA-21/0421**
Technische Bewertungsstelle: **DIBt - Deutsches Institut für Bautechnik, Berlin**
Notifizierte Stelle: **0769 - KIT - Karlsruher Institut für Technologie**

6.) Erklärte Leitung(en):
a) Mechanische Festigkeit und Standsicherheit (BWR 1)

Wesentliche Merkmale	Leistungswerte
Querkraftbeanspruchbarkeit der Verbindung	Siehe Anhang 1-19
Zugbeanspruchbarkeit der Verbindung	Siehe Anhang 1-19
Bemessungsbeanspruchbarkeit im Fall der Kombination von Zug-/Querkraften (Interaktion)	Siehe Anhang 1-19
Überprüfung der Verformungskapazität im Fall von temperaturbedingten Zwängungskraften	NPD
Haltbarkeit	NPD

b) Brandschutz (BWR 2)

Wesentliche Merkmale	Leistungswerte
Brandverhalten	A1

Die Leistung des vorstehenden Produkts entspricht der erklärten Leitung/den erklärten Leistungen. Für die Erstellung der Leistungserklärung im Einklang mit der Verordnung (EU) Nr. 305/2011 ist allein der oben genannte Hersteller verantwortlich.

Unterzeichnet für den Hersteller und im Namen des Herstellers von:

Dr. Jens Weber / Geschäftsführung

(Name und Funktion)

Bad Laasphe, 18.01.2022
(Ort und Datum der Ausstellung)

(Unterschrift)

Materials:

Fastener: stainless steel (A2) – EN ISO 3506
stainless steel (A4) – EN ISO 3506

Washer: stainless steel (A2/A4) – EN ISO 3506
with vulcanised EPDM seal

Component I: S280GD to S350GD – EN 10346

Component II: timber – EN 14081

Drilling capacity: $\Sigma t_i \leq 2 \times 1.00 \text{ mm}$

Timber substructures:

performance determined with

$M_{y,Rk} = 5.990 \text{ Nm}$ $l_b = 7 \text{ mm}$

$f_{ax,k} = 15.300 \text{ N/mm}^2$ for $l_{ef} \geq 20 \text{ mm}$

$t_{N,I}$	$l_{ef} \text{ [mm]}$												
	20	23	25	28	30	33	35	38	40	43	45		
$V_{R,k} \text{ [kN]}$ for $t_{N,I} =$													bearing resistance of component I
0.40	0.52	0.59	0.65	0.72	0.78	0.85	0.91	0.98	1.04	1.11	1.17	1.33	
0.50	0.52	0.59	0.65	0.72	0.78	0.85	0.91	0.98	1.04	1.11	1.17	1.70	
0.55	0.52	0.59	0.65	0.72	0.78	0.85	0.91	0.98	1.04	1.11	1.17	1.89	
0.63	0.52	0.59	0.65	0.72	0.78	0.85	0.91	0.98	1.04	1.11	1.17	2.19	
0.75	0.52	0.59	0.65	0.72	0.78	0.85	0.91	0.98	1.04	1.11	1.17	2.63	
0.88	0.52	0.59	0.65	0.72	0.78	0.85	0.91	0.98	1.04	1.11	1.17	3.11	
1.00	0.52	0.59	0.65	0.72	0.78	0.85	0.91	0.98	1.04	1.11	1.17	3.56	
$N_{R,k} \text{ [kN]}$ for $t_{N,I} =$													pull-through resistance of component I
0.40	0.95	0.95	0.95	0.95	0.95	0.95	0.95	0.95	0.95	0.95	0.95	0.95	
0.50	1.21	1.21	1.21	1.21	1.21	1.21	1.21	1.21	1.21	1.21	1.21	1.21	
0.55	1.35	1.35	1.35	1.35	1.35	1.35	1.35	1.35	1.35	1.35	1.35	1.35	
0.63	1.35	1.55	1.56	1.56	1.56	1.56	1.56	1.56	1.56	1.56	1.56	1.56	
0.75	1.35	1.55	1.69	1.87	1.87	1.87	1.87	1.87	1.87	1.87	1.87	1.87	
0.88	1.35	1.55	1.69	1.89	2.02	2.22	2.22	2.22	2.22	2.22	2.22	2.22	
1.00	1.35	1.55	1.69	1.89	2.02	2.23	2.36	2.53	2.53	2.53	2.53	2.53	
$N_{R,II,k} \text{ [kN]} =$	1.35	1.55	1.69	1.89	2.02	2.23	2.36	2.56	2.70	2.90	3.04		

– The values indicated above depending on the screw depth l_{ef} shall apply for $k_{mod} = 0.90$ and the timber strength class C24 ($\rho_k = 350 \text{ kg/m}^3$). For other values of k_{mod} and timber strength classes see Annex 3.

Fastening screws JF

Self-drilling screw
JF3-(FR-)4.9xL, JF6-(FR-)4.9xL
 with hexagon head or round head with TX-drive system and sealing washer $\geq \text{Ø}11 \text{ mm}$

Annex 5

Materials:

Fastener: stainless steel (A2) – EN ISO 3506
stainless steel (A4) – EN ISO 3506

Washer: stainless steel (A2/A4) – EN ISO 3506
with vulcanised EPDM seal

Component I: S280GD to S350GD – EN 10346

Component II: timber – EN 14081

Drilling capacity: $\Sigma t_i \leq 2 \times 1.00 \text{ mm}$

Timber substructures:

performance determined with

$M_{y,Rk} = 5.990 \text{ Nm}$ $l_b = 7 \text{ mm}$

$f_{ax,k} = 15.300 \text{ N/mm}^2$ for $l_{ef} \geq 20 \text{ mm}$

$t_{N,I}$	$l_{ef} \text{ [mm]}$												
	20	23	25	28	30	33	35	38	40	43	45		
$V_{R,k} \text{ [kN]}$ for $t_{N,I} =$													bearing resistance of component I
0.40	0.52	0.59	0.65	0.72	0.78	0.85	0.91	0.98	1.04	1.11	1.17	1.33	
0.50	0.52	0.59	0.65	0.72	0.78	0.85	0.91	0.98	1.04	1.11	1.17	1.70	
0.55	0.52	0.59	0.65	0.72	0.78	0.85	0.91	0.98	1.04	1.11	1.17	1.89	
0.63	0.52	0.59	0.65	0.72	0.78	0.85	0.91	0.98	1.04	1.11	1.17	2.19	
0.75	0.52	0.59	0.65	0.72	0.78	0.85	0.91	0.98	1.04	1.11	1.17	2.63	
0.88	0.52	0.59	0.65	0.72	0.78	0.85	0.91	0.98	1.04	1.11	1.17	3.11	
1.00	0.52	0.59	0.65	0.72	0.78	0.85	0.91	0.98	1.04	1.11	1.17	3.56	
$N_{R,k} \text{ [kN]}$ for $t_{N,I} =$													pull-through resistance of component I
0.40	1.35	1.38	1.38	1.38	1.38	1.38	1.38	1.38	1.38	1.38	1.38	1.38	
0.50	1.35	1.55	1.69	1.77	1.77	1.77	1.77	1.77	1.77	1.77	1.77	1.77	
0.55	1.35	1.55	1.69	1.89	1.96	1.96	1.96	1.96	1.96	1.96	1.96	1.96	
0.63	1.35	1.55	1.69	1.89	2.02	2.23	2.27	2.27	2.27	2.27	2.27	2.27	
0.75	1.35	1.55	1.69	1.89	2.02	2.23	2.36	2.56	2.70	2.73	2.73	2.73	
0.88	1.35	1.55	1.69	1.89	2.02	2.23	2.36	2.56	2.70	2.90	3.04	3.23	
1.00	1.35	1.55	1.69	1.89	2.02	2.23	2.36	2.56	2.70	2.90	3.04	3.69	
$N_{R,II,k} \text{ [kN]} =$	1.35	1.55	1.69	1.89	2.02	2.23	2.36	2.56	2.70	2.90	3.04		

– The values indicated above depending on the screw depth l_{ef} shall apply for $k_{mod} = 0.90$ and the timber strength class C24 ($\rho_k = 350 \text{ kg/m}^3$). For other values of k_{mod} and timber strength classes see Annex 3.

Fastening screws JF

Self-drilling screw
JF3-(FR-)4.9xL, JF6-(FR-)4.9xL
 with hexagon head or round head with TX-drive system and sealing washer $\geq \text{Ø}16 \text{ mm}$

Annex 6

Materials:

Fastener: stainless steel (A2) – EN ISO 3506
stainless steel (A4) – EN ISO 3506

Washer: stainless steel (A2/A4) – EN ISO 3506
with vulcanised EPDM seal

Component I: aluminium alloy
with $R_{m,min} = 165 \text{ N/mm}^2$ – EN 573

Component II: timber – EN 14081

Drilling capacity: $\Sigma t_i \leq 2.00 \text{ mm}$

Timber substructures:

performance determined with

$M_{y,Rk} = 5.990 \text{ Nm}$ $l_b = 7 \text{ mm}$

$f_{ax,k} = 15.300 \text{ N/mm}^2$ for $l_{ef} \geq 20 \text{ mm}$

$t_{N,i}$ [mm]	l_{ef} [mm]										
	20	22	24	26	28	30	32	34	36		
$V_{R,k}$ [kN] for $t_{N,i} =$	0.50	0.50	0.50	0.50	0.50	0.50	0.50	0.50	0.50	0.50	bearing resistance of component I
	0.60	0.52	0.57	0.62	0.66	0.66	0.66	0.66	0.66	0.66	
	0.70	0.52	0.57	0.62	0.68	0.73	0.78	0.82	0.82	0.82	
	0.80	0.52	0.57	0.62	0.68	0.73	0.78	0.83	0.88	0.94	
	0.90	0.52	0.57	0.62	0.68	0.73	0.78	0.83	0.88	0.94	
	1.00	0.52	0.57	0.62	0.68	0.73	0.78	0.83	0.88	0.94	
	1.20	0.52	0.57	0.62	0.68	0.73	0.78	0.83	0.88	0.94	
	1.50	0.52	0.57	0.62	0.68	0.73	0.78	0.83	0.88	0.94	
	2.00	0.52	0.57	0.62	0.68	0.73	0.78	0.83	0.88	0.94	
$N_{R,II,k}$ [kN] =	1.35	1.48	1.62	1.75	1.89	2.02	2.16	2.29	2.43	pull-through resistance of component I (see comment)	

- Pull-through resistance of component I according to EN 1999-1-4. chapter 8.3.3.1 or according to the specifications of the manufacturer of the aluminium profiles, see also Annex 4.
- The values indicated above depending on the screw depth l_{ef} shall apply to $k_{mod} = 0.90$ and the timber strength class C24 ($\rho_k = 350 \text{ kg/m}^3$). For other values of k_{mod} and strength classes see Annex 3.

Fastening screws JF

Self-drilling screw
JF3-(FR-)4.9xL, JF6-(FR-)4.9xL

with hexagon head or round head with TX-drive system and sealing washer $\geq \text{Ø}11 \text{ mm}$

Annex 7

Materials:

Fastener: stainless steel (A2) – EN ISO 3506
stainless steel (A4) – EN ISO 3506

Washer: stainless steel (A2/A4) – EN ISO 3506
with vulcanised EPDM seal

Component I: aluminium alloy
with $R_{m,min} = 215 \text{ N/mm}^2$ – EN 573

Component II: timber – EN 14081

Drilling capacity: $\Sigma t_i \leq 2.00 \text{ mm}$

Timber substructures:

performance determined with

$M_{y,Rk} = 5.990 \text{ Nm}$ $l_b = 7 \text{ mm}$

$f_{ax,k} = 15.300 \text{ N/mm}^2$ for $l_{ef} \geq 20 \text{ mm}$

$t_{N,I}$ [mm]	l_{ef} [mm]										
	20	22	24	26	28	30	32	34	36		
$V_{R,k}$ [kN] for $t_{N,I} =$	0.50	0.52	0.57	0.62	0.66	0.66	0.66	0.66	0.66	0.66	bearing resistance of component I
	0.60	0.52	0.57	0.62	0.68	0.73	0.78	0.83	0.87	0.87	
	0.70	0.52	0.57	0.62	0.68	0.73	0.78	0.83	0.88	0.94	
	0.80	0.52	0.57	0.62	0.68	0.73	0.78	0.83	0.88	0.94	
	0.90	0.52	0.57	0.62	0.68	0.73	0.78	0.83	0.88	0.94	
	1.00	0.52	0.57	0.62	0.68	0.73	0.78	0.83	0.88	0.94	
	1.20	0.52	0.57	0.62	0.68	0.73	0.78	0.83	0.88	0.94	
	1.50	0.52	0.57	0.62	0.68	0.73	0.78	0.83	0.88	0.94	
	2.00	0.52	0.57	0.62	0.68	0.73	0.78	0.83	0.88	0.94	
$N_{R,II,k}$ [kN] =	1.35	1.48	1.62	1.75	1.89	2.02	2.16	2.29	2.43	pull-through resistance of component I (see comment)	

- Pull-through resistance of component I according to EN 1999-1-4. chapter 8.3.3.1 or according to the specifications of the manufacturer of the aluminium profiles, see also Annex 4.
- The values indicated above depending on the screw depth l_{ef} shall apply to $k_{mod} = 0.90$ and the timber strength class C24 ($\rho_k = 350 \text{ kg/m}^3$). For other values of k_{mod} and strength classes see Annex 3.

Fastening screws JF

Self-drilling screw
JF3-(FR-)4.9xL, JF6-(FR-)4.9xL

with hexagon head or round head with TX-drive system and sealing washer $\geq \text{Ø}11 \text{ mm}$

Annex 8

Materials:

Fastener: stainless steel (A2) – EN ISO 3506
stainless steel (A4) – EN ISO 3506

Washer: stainless steel (A2/A4) – EN ISO 3506
with vulcanised EPDM seal

Component I: S280GD to S350GD – EN 10346

Component II: timber – EN 14081

Drilling capacity: $\Sigma t_i \leq 2 \times 1.00 \text{ mm}$

Timber substructures:

performance determined with

$M_{y,Rk} = 5.990 \text{ Nm}$ $l_b = 7 \text{ mm}$

$f_{ax,k} = 15.300 \text{ N/mm}^2$ for $l_{ef} \geq 20 \text{ mm}$

$t_{N,I}$	$l_{ef} \text{ [mm]}$													
	[mm]	20	23	25	28	30	33	35	38	40	43		45	
$V_{R,k} \text{ [kN]}$ for $t_{N,I} =$	0.40	0.52	0.59	0.65	0.72	0.78	0.85	0.91	0.98	1.04	1.11	1.17	bearing resistance of component I	
	0.50	0.52	0.59	0.65	0.72	0.78	0.85	0.91	0.98	1.04	1.11	1.17		1.70
	0.55	0.52	0.59	0.65	0.72	0.78	0.85	0.91	0.98	1.04	1.11	1.17		1.89
	0.63	0.52	0.59	0.65	0.72	0.78	0.85	0.91	0.98	1.04	1.11	1.17		2.19
	0.75	0.52	0.59	0.65	0.72	0.78	0.85	0.91	0.98	1.04	1.11	1.17		2.63
	0.88	0.52	0.59	0.65	0.72	0.78	0.85	0.91	0.98	1.04	1.11	1.17		3.11
	1.00	0.52	0.59	0.65	0.72	0.78	0.85	0.91	0.98	1.04	1.11	1.17		3.56
$N_{R,k} \text{ [kN]}$ for $t_{N,I} =$	0.40	0.95	0.95	0.95	0.95	0.95	0.95	0.95	0.95	0.95	0.95	0.95	pull-through resistance of component I	
	0.50	1.21	1.21	1.21	1.21	1.21	1.21	1.21	1.21	1.21	1.21	1.21		1.21
	0.55	1.35	1.35	1.35	1.35	1.35	1.35	1.35	1.35	1.35	1.35	1.35		1.35
	0.63	1.35	1.55	1.56	1.56	1.56	1.56	1.56	1.56	1.56	1.56	1.56		1.56
	0.75	1.35	1.55	1.69	1.87	1.87	1.87	1.87	1.87	1.87	1.87	1.87		1.87
	0.88	1.35	1.55	1.69	1.89	2.02	2.22	2.22	2.22	2.22	2.22	2.22		2.22
1.00	1.35	1.55	1.69	1.89	2.02	2.23	2.36	2.53	2.53	2.53	2.53	2.53		
$N_{R,II,k} \text{ [kN]} =$		1.35	1.55	1.69	1.89	2.02	2.23	2.36	2.56	2.70	2.90	3.04		

– The values indicated above depending on the screw depth l_{ef} shall apply for $k_{mod} = 0.90$ and the timber strength class C24 ($\rho_k = 350 \text{ kg/m}^3$). For other values of k_{mod} and timber strength classes see Annex 3.

Fastening screws JF

Self-drilling screw
JF3-(FR-)Plus-4.9xL, JF6-(FR-)Plus-4.9xL

with hexagon head or round head with TX-drive system and sealing washer $\geq \text{Ø}11 \text{ mm}$

Annex 9

Materials:

Fastener: stainless steel (A2) – EN ISO 3506
stainless steel (A4) – EN ISO 3506

Washer: stainless steel (A2/A4) – EN ISO 3506
with vulcanised EPDM seal

Component I: S280GD to S350GD – EN 10346

Component II: timber – EN 14081

Drilling capacity: $\Sigma t_i \leq 2 \times 1.00 \text{ mm}$

Timber substructures:

performance determined with

$M_{y,Rk} = 5.990 \text{ Nm}$ $l_b = 7 \text{ mm}$

$f_{ax,k} = 15.300 \text{ N/mm}^2$ for $l_{ef} \geq 20 \text{ mm}$

$t_{N,I}$	$l_{ef} \text{ [mm]}$													
	[mm]	20	23	25	28	30	33	35	38	40	43		45	
$V_{R,k} \text{ [kN]}$ for $t_{N,I} =$	0.40	0.52	0.59	0.65	0.72	0.78	0.85	0.91	0.98	1.04	1.11	1.17	1.33	bearing resistance of component I
	0.50	0.52	0.59	0.65	0.72	0.78	0.85	0.91	0.98	1.04	1.11	1.17	1.70	
	0.55	0.52	0.59	0.65	0.72	0.78	0.85	0.91	0.98	1.04	1.11	1.17	1.89	
	0.63	0.52	0.59	0.65	0.72	0.78	0.85	0.91	0.98	1.04	1.11	1.17	2.19	
	0.75	0.52	0.59	0.65	0.72	0.78	0.85	0.91	0.98	1.04	1.11	1.17	2.63	
	0.88	0.52	0.59	0.65	0.72	0.78	0.85	0.91	0.98	1.04	1.11	1.17	3.11	
	1.00	0.52	0.59	0.65	0.72	0.78	0.85	0.91	0.98	1.04	1.11	1.17	3.56	
$N_{R,k} \text{ [kN]}$ for $t_{N,I} =$	0.40	1.35	1.38	1.38	1.38	1.38	1.38	1.38	1.38	1.38	1.38	1.38	1.38	pull-through resistance of component I
	0.50	1.35	1.55	1.69	1.77	1.77	1.77	1.77	1.77	1.77	1.77	1.77	1.77	
	0.55	1.35	1.55	1.69	1.89	1.96	1.96	1.96	1.96	1.96	1.96	1.96	1.96	
	0.63	1.35	1.55	1.69	1.89	2.02	2.23	2.27	2.27	2.27	2.27	2.27	2.27	
	0.75	1.35	1.55	1.69	1.89	2.02	2.23	2.36	2.56	2.70	2.73	2.73	2.73	
	0.88	1.35	1.55	1.69	1.89	2.02	2.23	2.36	2.56	2.70	2.90	3.04	3.23	
	1.00	1.35	1.55	1.69	1.89	2.02	2.23	2.36	2.56	2.70	2.90	3.04	3.69	
$N_{R,II,k} \text{ [kN]} =$	1.35	1.55	1.69	1.89	2.02	2.23	2.36	2.56	2.70	2.90	3.04			

– The values indicated above depending on the screw depth l_{ef} shall apply for $k_{mod} = 0.90$ and the timber strength class C24 ($\rho_k = 350 \text{ kg/m}^3$). For other values of k_{mod} and timber strength classes see Annex 3.

Fastening screws JF

Self-drilling screw
JF3-(FR-)Plus-4.9xL, JF6-(FR-)Plus-4.9xL
 with hexagon head or round head with TX-drive system and sealing washer $\geq \text{Ø}16 \text{ mm}$

Annex 10

Materials:

Fastener: stainless steel (A2) – EN ISO 3506
stainless steel (A4) – EN ISO 3506

Washer: stainless steel (A2/A4) – EN ISO 3506
with vulcanised EPDM seal

Component I: aluminium alloy
with $R_{m,min} = 165 \text{ N/mm}^2$ – EN 573

Component II: timber – EN 14081

Drilling capacity: $\Sigma t_i \leq 2.00 \text{ mm}$

Timber substructures:
performance determined with

$M_{y,Rk} = 5.990 \text{ Nm}$ $l_b = 7 \text{ mm}$

$f_{ax,k} = 15.300 \text{ N/mm}^2$ for $l_{ef} \geq 20 \text{ mm}$

$t_{N,i}$ [mm]	l_{ef} [mm]										
	20	22	24	26	28	30	32	34	36		
$V_{R,k}$ [kN] for $t_{N,i} =$	0.50	0.50	0.50	0.50	0.50	0.50	0.50	0.50	0.50	0.50	bearing resistance of component I
	0.60	0.52	0.57	0.62	0.66	0.66	0.66	0.66	0.66	0.66	
	0.70	0.52	0.57	0.62	0.68	0.73	0.78	0.82	0.82	0.82	
	0.80	0.52	0.57	0.62	0.68	0.73	0.78	0.83	0.88	0.94	
	0.90	0.52	0.57	0.62	0.68	0.73	0.78	0.83	0.88	0.94	
	1.00	0.52	0.57	0.62	0.68	0.73	0.78	0.83	0.88	0.94	
	1.20	0.52	0.57	0.62	0.68	0.73	0.78	0.83	0.88	0.94	
	1.50	0.52	0.57	0.62	0.68	0.73	0.78	0.83	0.88	0.94	
	2.00	0.52	0.57	0.62	0.68	0.73	0.78	0.83	0.88	0.94	
$N_{R,II,k}$ [kN] =	1.35	1.48	1.62	1.75	1.89	2.02	2.16	2.29	2.43	pull-through resistance of component I (see comment)	

- Pull-through resistance of component I according to EN 1999-1-4. chapter 8.3.3.1 or according to the specifications of the manufacturer of the aluminium profiles, see also Annex 4.
- The values indicated above depending on the screw depth l_{ef} shall apply to $k_{mod} = 0.90$ and the timber strength class C24 ($\rho_k = 350 \text{ kg/m}^3$). For other values of k_{mod} and strength classes see Annex 3.

Fastening screws JF

Self-drilling screw
JF3-(FR-)Plus-4.9xL, JF6-(FR-)Plus-4.9xL

with hexagon head or round head with TX-drive system and sealing washer $\geq \text{Ø}11 \text{ mm}$

Annex 11

Materials:

Fastener: stainless steel (A2) – EN ISO 3506
stainless steel (A4) – EN ISO 3506

Washer: stainless steel (A2/A4) – EN ISO 3506
with vulcanised EPDM seal

Component I: aluminium alloy
with $R_{m,min} = 215 \text{ N/mm}^2$ – EN 573

Component II: timber – EN 14081

Drilling capacity: $\Sigma t_i \leq 2.00 \text{ mm}$

Timber substructures:

performance determined with

$M_{y,Rk} = 5.990 \text{ Nm}$ $l_b = 7 \text{ mm}$

$f_{ax,k} = 15.300 \text{ N/mm}^2$ for $l_{ef} \geq 20 \text{ mm}$

$t_{N,I}$ [mm]	l_{ef} [mm]										
	20	22	24	26	28	30	32	34	36		
$V_{R,k}$ [kN] for $t_{N,I} =$	0.50	0.52	0.57	0.62	0.66	0.66	0.66	0.66	0.66	0.66	bearing resistance of component I
	0.60	0.52	0.57	0.62	0.68	0.73	0.78	0.83	0.87	0.87	
	0.70	0.52	0.57	0.62	0.68	0.73	0.78	0.83	0.88	0.94	
	0.80	0.52	0.57	0.62	0.68	0.73	0.78	0.83	0.88	0.94	
	0.90	0.52	0.57	0.62	0.68	0.73	0.78	0.83	0.88	0.94	
	1.00	0.52	0.57	0.62	0.68	0.73	0.78	0.83	0.88	0.94	
	1.20	0.52	0.57	0.62	0.68	0.73	0.78	0.83	0.88	0.94	
	1.50	0.52	0.57	0.62	0.68	0.73	0.78	0.83	0.88	0.94	
	2.00	0.52	0.57	0.62	0.68	0.73	0.78	0.83	0.88	0.94	
$N_{R,II,k}$ [kN] =	1.35	1.48	1.62	1.75	1.89	2.02	2.16	2.29	2.43	pull-through resistance of component I (see comment)	

- Pull-through resistance of component I according to EN 1999-1-4. chapter 8.3.3.1 or according to the specifications of the manufacturer of the aluminium profiles, see also Annex 4.
- The values indicated above depending on the screw depth l_{ef} shall apply to $k_{mod} = 0.90$ and the timber strength class C24 ($\rho_k = 350 \text{ kg/m}^3$). For other values of k_{mod} and strength classes see Annex 3.

Fastening screws JF

Self-drilling screw
JF3-(FR-)Plus-4.9xL, JF6-(FR-)Plus-4.9xL

with hexagon head or round head with TX-drive system and sealing washer $\geq \phi 11 \text{ mm}$

Annex 12

Materials:
 Fastener: stainless steel (A2) – EN ISO 3506
 stainless steel (A4) – EN ISO 3506
 Washer: stainless steel (A2/A4) – EN ISO 3506
 with vulcanised EPDM seal
 Component I: S280GD to S350GD – EN 10346
 Component II: timber – EN 14081

Drilling capacity: $\Sigma t_i \leq 2 \times 1.00 \text{ mm}$

Timber substructures:
 performance determined with
 $M_{y,Rk} = 10.744 \text{ Nm}$ $l_b = 9 \text{ mm}$
 $f_{ax,k} = 12.200 \text{ N/mm}^2$ for $l_{ef} \geq 27 \text{ mm}$

$t_{N,I}$	$l_{ef} \text{ [mm]}$																
	[mm]	27	30	33	36	39	42	45	48	51	54	57	60	63		66	
$V_{R,k} \text{ [kN]}$ for $t_{N,I} =$	0.40	0.88	0.98	1.08	1.17	1.27	1.37	1.47	1.57	1.66	1.76	1.77	1.77	1.77	1.77	1.77	bearing resistance of component I
	0.50	0.88	0.98	1.08	1.17	1.27	1.37	1.47	1.57	1.66	1.76	1.86	1.96	2.06	2.15	2.26	
	0.55	0.88	0.98	1.08	1.17	1.27	1.37	1.47	1.57	1.66	1.76	1.86	1.96	2.06	2.15	2.51	
	0.63	0.88	0.98	1.08	1.17	1.27	1.37	1.47	1.57	1.66	1.76	1.86	1.96	2.06	2.15	2.90	
	0.75	0.88	0.98	1.08	1.17	1.27	1.37	1.47	1.57	1.66	1.76	1.86	1.96	2.06	2.15	3.10	
	0.88	0.88	0.98	1.08	1.17	1.27	1.37	1.47	1.57	1.66	1.76	1.86	1.96	2.06	2.15	3.20	
	1.00	0.88	0.98	1.08	1.17	1.27	1.37	1.47	1.57	1.66	1.76	1.86	1.96	2.06	2.15	3.60	
$N_{R,k} \text{ [kN]}$ for $t_{N,I} =$	0.40	0.95	0.95	0.95	0.95	0.95	0.95	0.95	0.95	0.95	0.95	0.95	0.95	0.95	0.95	0.95	pull-through resistance of component I
	0.50	1.21	1.21	1.21	1.21	1.21	1.21	1.21	1.21	1.21	1.21	1.21	1.21	1.21	1.21	1.21	
	0.55	1.35	1.35	1.35	1.35	1.35	1.35	1.35	1.35	1.35	1.35	1.35	1.35	1.35	1.35	1.35	
	0.63	1.56	1.56	1.56	1.56	1.56	1.56	1.56	1.56	1.56	1.56	1.56	1.56	1.56	1.56	1.56	
	0.75	1.87	1.87	1.87	1.87	1.87	1.87	1.87	1.87	1.87	1.87	1.87	1.87	1.87	1.87	1.87	
	0.88	2.02	2.22	2.22	2.22	2.22	2.22	2.22	2.22	2.22	2.22	2.22	2.22	2.22	2.22	2.22	
	1.00	2.02	2.24	2.46	2.53	2.53	2.53	2.53	2.53	2.53	2.53	2.53	2.53	2.53	2.53	2.53	
$N_{R,II,k} \text{ [kN]} =$	2.02	2.24	2.46	2.69	2.91	3.14	3.36	3.58	3.81	4.03	4.26	4.48	4.70	4.93			

– The values indicated above depending on the screw depth l_{ef} shall apply for $k_{mod} = 0.90$ and the timber strength class C24 ($\rho_k = 350 \text{ kg/m}^3$). For other values of k_{mod} and timber strength classes see Annex 3.

Fastening screws JF

Self-drilling screw
JF3-(FR-)Plus-6.8xL, JF6-(FR-)Plus-6.8xL
 with hexagon head or round head with TX-drive system and sealing washer $\geq \text{Ø}11 \text{ mm}$

Annex 13

Materials:

Fastener: stainless steel (A2) – EN ISO 3506
stainless steel (A4) – EN ISO 3506

Washer: stainless steel (A2/A4) – EN ISO 3506
with vulcanised EPDM seal

Component I: S280GD to S350GD – EN 10346

Component II: timber – EN 14081

Drilling capacity: $\Sigma t_i \leq 2 \times 1.00 \text{ mm}$

Timber substructures:

performance determined with

$M_{y,Rk} = 10.744 \text{ Nm}$ $l_b = 9 \text{ mm}$

$f_{ax,k} = 12.200 \text{ N/mm}^2$ for $l_{ef} \geq 27 \text{ mm}$

$t_{N,I}$	$l_{ef} \text{ [mm]}$																
	[mm]	27	30	33	36	39	42	45	48	51	54	57	60	63		66	
$V_{R,k} \text{ [kN]} \text{ for } t_{N,I} =$	0.40	0.88	0.98	1.08	1.17	1.27	1.37	1.47	1.57	1.66	1.76	1.77	1.77	1.77	1.77	1.77	bearing resistance of component I
	0.50	0.88	0.98	1.08	1.17	1.27	1.37	1.47	1.57	1.66	1.76	1.86	1.96	2.06	2.15	2.26	
	0.55	0.88	0.98	1.08	1.17	1.27	1.37	1.47	1.57	1.66	1.76	1.86	1.96	2.06	2.15	2.51	
	0.63	0.88	0.98	1.08	1.17	1.27	1.37	1.47	1.57	1.66	1.76	1.86	1.96	2.06	2.15	2.90	
	0.75	0.88	0.98	1.08	1.17	1.27	1.37	1.47	1.57	1.66	1.76	1.86	1.96	2.06	2.15	3.10	
	0.88	0.88	0.98	1.08	1.17	1.27	1.37	1.47	1.57	1.66	1.76	1.86	1.96	2.06	2.15	3.20	
	1.00	0.88	0.98	1.08	1.17	1.27	1.37	1.47	1.57	1.66	1.76	1.86	1.96	2.06	2.15	3.60	
$N_{R,k} \text{ [kN]} \text{ for } t_{N,I} =$	0.40	1.38	1.38	1.38	1.38	1.38	1.38	1.38	1.38	1.38	1.38	1.38	1.38	1.38	1.38	1.38	pull-through resistance of component I
	0.50	1.77	1.77	1.77	1.77	1.77	1.77	1.77	1.77	1.77	1.77	1.77	1.77	1.77	1.77	1.77	
	0.55	1.96	1.96	1.96	1.96	1.96	1.96	1.96	1.96	1.96	1.96	1.96	1.96	1.96	1.96	1.96	
	0.63	2.02	2.24	2.27	2.27	2.27	2.27	2.27	2.27	2.27	2.27	2.27	2.27	2.27	2.27	2.27	
	0.75	2.02	2.24	2.46	2.69	2.73	2.73	2.73	2.73	2.73	2.73	2.73	2.73	2.73	2.73	2.73	
	0.88	2.02	2.24	2.46	2.69	2.91	3.14	3.23	3.23	3.23	3.23	3.23	3.23	3.23	3.23	3.23	
	1.00	2.02	2.24	2.46	2.69	2.91	3.14	3.36	3.58	3.69	3.69	3.69	3.69	3.69	3.69	3.69	
$N_{R,II,k} \text{ [kN]} =$	2.02	2.24	2.46	2.69	2.91	3.14	3.36	3.58	3.81	4.03	4.26	4.48	4.70	4.93			

– The values indicated above depending on the screw depth l_{ef} shall apply for $k_{mod} = 0.90$ and the timber strength class C24 ($\rho_k = 350 \text{ kg/m}^3$). For other values of k_{mod} and timber strength classes see Annex 3.

Fastening screws JF

Self-drilling screw
JF3-(FR-)Plus-6.8xL, JF6-(FR-)Plus-6.8xL
 with hexagon head or round head with TX-drive system and sealing washer $\geq \text{Ø}16 \text{ mm}$

Annex 14

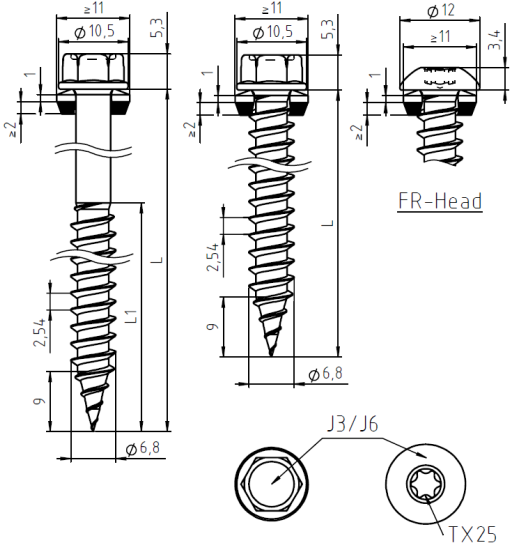

Materials:

Fastener: stainless steel (A2) – EN ISO 3506
stainless steel (A4) – EN ISO 3506

Washer: stainless steel (A2/A4) – EN ISO 3506
with vulcanised EPDM seal

Component I: S280GD to S350GD – EN 10346

Component II: timber – EN 14081

Drilling capacity: $\Sigma t_i \leq 2 \times 1.00 \text{ mm}$

Timber substructures:

performance determined with

$M_{y,Rk} = 10.744 \text{ Nm}$ $l_b = 9 \text{ mm}$

$f_{ax,k} = 12.200 \text{ N/mm}^2$ for $l_{ef} \geq 27 \text{ mm}$

$t_{N,I}$	$l_{ef} \text{ [mm]}$															
	[mm]	27	30	33	36	39	42	45	48	51	54	57	60	63		66
$V_{R,k} \text{ [kN]} \text{ for } t_{N,I} =$	0.40	0.88	0.98	1.08	1.17	1.27	1.37	1.47	1.57	1.66	1.76	1.77	1.77	1.77	1.77	1.77
	0.50	0.88	0.98	1.08	1.17	1.27	1.37	1.47	1.57	1.66	1.76	1.86	1.96	2.06	2.15	2.26
	0.55	0.88	0.98	1.08	1.17	1.27	1.37	1.47	1.57	1.66	1.76	1.86	1.96	2.06	2.15	2.51
	0.63	0.88	0.98	1.08	1.17	1.27	1.37	1.47	1.57	1.66	1.76	1.86	1.96	2.06	2.15	2.90
	0.75	0.88	0.98	1.08	1.17	1.27	1.37	1.47	1.57	1.66	1.76	1.86	1.96	2.06	2.15	3.10
	0.88	0.88	0.98	1.08	1.17	1.27	1.37	1.47	1.57	1.66	1.76	1.86	1.96	2.06	2.15	3.20
	1.00	0.88	0.98	1.08	1.17	1.27	1.37	1.47	1.57	1.66	1.76	1.86	1.96	2.06	2.15	3.60
$N_{R,k} \text{ [kN]} \text{ for } t_{N,I} =$	0.40	1.64	1.64	1.64	1.64	1.64	1.64	1.64	1.64	1.64	1.64	1.64	1.64	1.64	1.64	1.64
	0.50	1.90	1.90	1.90	1.90	1.90	1.90	1.90	1.90	1.90	1.90	1.90	1.90	1.90	1.90	1.90
	0.55	2.02	2.24	2.33	2.33	2.33	2.33	2.33	2.33	2.33	2.33	2.33	2.33	2.33	2.33	2.33
	0.63	2.02	2.24	2.46	2.69	2.91	3.03	3.03	3.03	3.03	3.03	3.03	3.03	3.03	3.03	3.03
	0.75	2.02	2.24	2.46	2.69	2.91	3.03	3.03	3.03	3.03	3.03	3.03	3.03	3.03	3.03	3.03
	0.88	2.02	2.24	2.46	2.69	2.91	3.14	3.23	3.23	3.23	3.23	3.23	3.23	3.23	3.23	3.23
	1.00	2.02	2.24	2.46	2.69	2.91	3.14	3.36	3.58	3.69	3.69	3.69	3.69	3.69	3.69	3.69
$N_{R,II,k} \text{ [kN]} =$	2.02	2.24	2.46	2.69	2.91	3.14	3.36	3.58	3.81	4.03	4.26	4.48	4.70	4.93		

– The values indicated above depending on the screw depth l_{ef} shall apply for $k_{mod} = 0.90$ and the timber strength class C24 ($\rho_k = 350 \text{ kg/m}^3$). For other values of k_{mod} and timber strength classes see Annex 3.

Fastening screws JF

Self-drilling screw
JF3-(FR-)Plus-6.8xL, JF6-(FR-)Plus-6.8xL
 with hexagon head or round head with TX-drive system and sealing washer $\geq \text{Ø}19 \text{ mm}$

Annex 15

Materials:
 Fastener: stainless steel (A2) – EN ISO 3506
 stainless steel (A4) – EN ISO 3506
 Washer: stainless steel (A2/A4) – EN ISO 3506
 with vulcanised EPDM seal
 Component I: S280GD to S350GD – EN 10346
 Component II: timber – EN 14081

Drilling capacity: $\Sigma t_i \leq 2 \times 1.00 \text{ mm}$

Timber substructures:
 performance determined with
 $M_{y,Rk} = 10.744 \text{ Nm}$ $l_b = 9 \text{ mm}$
 $f_{ax,k} = 12.200 \text{ N/mm}^2$ for $l_{ef} \geq 27 \text{ mm}$

$t_{N,I}$ [mm]	l_{ef} [mm]																
	27	30	33	36	39	42	45	48	51	54	57	60	63	66			
$V_{R,k}$ [kN] for $t_{N,I} =$	0.40	0.88	0.98	1.08	1.17	1.27	1.37	1.47	1.57	1.66	1.76	1.77	1.77	1.77	1.77	1.77	bearing resistance of component I
	0.50	0.88	0.98	1.08	1.17	1.27	1.37	1.47	1.57	1.66	1.76	1.86	1.96	2.06	2.15	2.15	2.26
	0.55	0.88	0.98	1.08	1.17	1.27	1.37	1.47	1.57	1.66	1.76	1.86	1.96	2.06	2.15	2.15	2.51
	0.63	0.88	0.98	1.08	1.17	1.27	1.37	1.47	1.57	1.66	1.76	1.86	1.96	2.06	2.15	2.15	2.90
	0.75	0.88	0.98	1.08	1.17	1.27	1.37	1.47	1.57	1.66	1.76	1.86	1.96	2.06	2.15	2.15	3.10
	0.88	0.88	0.98	1.08	1.17	1.27	1.37	1.47	1.57	1.66	1.76	1.86	1.96	2.06	2.15	2.15	3.20
	1.00	0.88	0.98	1.08	1.17	1.27	1.37	1.47	1.57	1.66	1.76	1.86	1.96	2.06	2.15	2.15	3.60
$N_{R,k}$ [kN] for $t_{N,I} =$	0.40	1.90	1.90	1.90	1.90	1.90	1.90	1.90	1.90	1.90	1.90	1.90	1.90	1.90	1.90	1.90	pull-through resistance of component I
	0.50	2.02	2.21	2.21	2.21	2.21	2.21	2.21	2.21	2.21	2.21	2.21	2.21	2.21	2.21	2.21	2.21
	0.55	2.02	2.24	2.46	2.69	2.77	2.77	2.77	2.77	2.77	2.77	2.77	2.77	2.77	2.77	2.77	2.77
	0.63	2.02	2.24	2.46	2.69	2.91	3.14	3.33	3.33	3.33	3.33	3.33	3.33	3.33	3.33	3.33	3.33
	0.75	2.02	2.24	2.46	2.69	2.91	3.14	3.36	3.58	3.67	3.67	3.67	3.67	3.67	3.67	3.67	3.67
	0.88	2.02	2.24	2.46	2.69	2.91	3.14	3.36	3.58	3.67	3.67	3.67	3.67	3.67	3.67	3.67	3.67
	1.00	2.02	2.24	2.46	2.69	2.91	3.14	3.36	3.58	3.69	3.69	3.69	3.69	3.69	3.69	3.69	3.69
$N_{R,II,k}$ [kN] =	2.02	2.24	2.46	2.69	2.91	3.14	3.36	3.58	3.81	4.03	4.26	4.48	4.70	4.93			

– The values indicated above depending on the screw depth l_{ef} shall apply for $k_{mod} = 0.90$ and the timber strength class C24 ($\rho_k = 350 \text{ kg/m}^3$). For other values of k_{mod} and timber strength classes see Annex 3.

Fastening screws JF

Self-drilling screw
JF3-(FR-)Plus-6.8xL, JF6-(FR-)Plus-6.8xL
 with hexagon head or round head with TX-drive system and sealing washer $\geq \text{Ø}22 \text{ mm}$

Annex 16

Materials:

Fastener: stainless steel (A2) – EN ISO 3506
stainless steel (A4) – EN ISO 3506

Washer: stainless steel (A2/A4) – EN ISO 3506
with vulcanised EPDM seal

Component I: aluminium alloy
with $R_{m,min} = 165 \text{ N/mm}^2$ – EN 573

Component II: timber – EN 14081

Drilling capacity: $\Sigma t_i \leq 1.50 \text{ mm}$

Timber substructures:

performance determined with

$M_{y,Rk} = 10.744 \text{ Nm}$ $l_b = 9 \text{ mm}$

$f_{ax,k} = 12.200 \text{ N/mm}^2$ for $l_{ef} \geq 27 \text{ mm}$

$t_{N,I}$ [mm]	l_{ef} [mm]																
	27	30	33	36	39	42	45	48	51	54	57	60	63	66			
$V_{R,k}$ [kN] for $t_{N,I} =$	0.50	0.88	0.92	0.92	0.92	0.92	0.92	0.92	0.92	0.92	0.92	0.92	0.92	0.92	0.92	0.92	bearing resistance of component I
	0.60	0.88	0.98	1.08	1.15	1.15	1.15	1.15	1.15	1.15	1.15	1.15	1.15	1.15	1.15	1.15	
	0.70	0.88	0.98	1.08	1.17	1.27	1.37	1.38	1.38	1.38	1.38	1.38	1.38	1.38	1.38	1.38	
	0.80	0.88	0.98	1.08	1.17	1.27	1.37	1.47	1.57	1.61	1.61	1.61	1.61	1.61	1.61	1.61	
	0.90	0.88	0.98	1.08	1.17	1.27	1.37	1.47	1.57	1.66	1.76	1.84	1.84	1.84	1.84	1.84	
	1.00	0.88	0.98	1.08	1.17	1.27	1.37	1.47	1.57	1.66	1.76	1.86	1.96	2.06	2.07	2.07	
	1.20	0.88	0.98	1.08	1.17	1.27	1.37	1.47	1.57	1.66	1.76	1.86	1.96	2.06	2.15	2.38	
	1.50	0.88	0.98	1.08	1.17	1.27	1.37	1.47	1.57	1.66	1.76	1.86	1.96	2.06	2.15	2.76	
	2.00	—	—	—	—	—	—	—	—	—	—	—	—	—	—	—	
$N_{R,II,k}$ [kN] =		2.02	2.24	2.46	2.69	2.91	3.14	3.36	3.58	3.81	4.03	4.26	4.48	4.70	4.93		pull-through resistance of component I (see comment)

- Pull-through resistance of component I according to EN 1999-1-4. chapter 8.3.3.1 or according to the specifications of the manufacturer of the aluminium profiles, see also Annex 4.
- The values indicated above. depending on the screw depth l_{ef} shall apply to $k_{mod} = 0.90$ and the timber strength class C24 ($\rho_k = 350 \text{ kg/m}^3$). For other values of k_{mod} and strength classes see Annex 3.

Fastening screws JF

Self-drilling screw
JF3-(FR-)Plus-6.8xL, JF6-(FR-)Plus-6.8xL

with hexagon head or round head with TX-drive system and sealing washer $\geq \phi 11 \text{ mm}$

Annex 17

Materials:

Fastener: stainless steel (A2) – EN ISO 3506
stainless steel (A4) – EN ISO 3506

Washer: stainless steel (A2/A4) – EN ISO 3506
with vulcanised EPDM seal

Component I: aluminium alloy
with $R_{m,min} = 215 \text{ N/mm}^2$ – EN 573

Component II: timber – EN 14081

Drilling capacity: $\Sigma t_i \leq 1.50 \text{ mm}$

Timber substructures:

performance determined with

$M_{y,Rk} = 10.744 \text{ Nm}$ $l_b = 9 \text{ mm}$

$f_{ax,k} = 12.200 \text{ N/mm}^2$ for $l_{ef} \geq 27 \text{ mm}$

$t_{N,i}$	$l_{ef} \text{ [mm]}$															
	[mm]	27	30	33	36	39	42	45	48	51	54	57	60	63		66
$V_{R,k} \text{ [kN]} \text{ for } t_{N,i} =$	0.50	0.88	0.98	1.08	1.17	1.20	1.20	1.20	1.20	1.20	1.20	1.20	1.20	1.20	1.20	1.20
	0.60	0.88	0.98	1.08	1.17	1.27	1.37	1.47	1.50	1.50	1.50	1.50	1.50	1.50	1.50	1.50
	0.70	0.88	0.98	1.08	1.17	1.27	1.37	1.47	1.57	1.66	1.76	1.80	1.80	1.80	1.80	1.80
	0.80	0.88	0.98	1.08	1.17	1.27	1.37	1.47	1.57	1.66	1.76	1.86	1.96	2.06	2.10	2.10
	0.90	0.88	0.98	1.08	1.17	1.27	1.37	1.47	1.57	1.66	1.76	1.86	1.96	2.06	2.15	2.40
	1.00	0.88	0.98	1.08	1.17	1.27	1.37	1.47	1.57	1.66	1.76	1.86	1.96	2.06	2.15	2.70
	1.20	0.88	0.98	1.08	1.17	1.27	1.37	1.47	1.57	1.66	1.76	1.86	1.96	2.06	2.15	3.10
	1.50	0.88	0.98	1.08	1.17	1.27	1.37	1.47	1.57	1.66	1.76	1.86	1.96	2.06	2.15	3.60
	2.00	—	—	—	—	—	—	—	—	—	—	—	—	—	—	—
$N_{R,II,k} \text{ [kN]} =$		2.02	2.24	2.46	2.69	2.91	3.14	3.36	3.58	3.81	4.03	4.26	4.48	4.70	4.93	pull-through resistance of component I (see comment)

- Pull-through resistance of component I according to EN 1999-1-4. chapter 8.3.3.1 or according to the specifications of the manufacturer of the aluminium profiles, see also Annex 4.
- The values indicated above. depending on the screw depth l_{ef} shall apply to $k_{mod} = 0.90$ and the timber strength class C24 ($\rho_k = 350 \text{ kg/m}^3$). For other values of k_{mod} and strength classes see Annex 3.

Fastening screws JF

Self-drilling screw
JF3-(FR-)Plus-6.8xL, JF6-(FR-)Plus-6.8xL

with hexagon head or round head with TX-drive system and sealing washer $\geq \phi 11 \text{ mm}$

Annex 18

Materials:

Fastener: stainless steel (A2) – EN ISO 3506
stainless steel (A4) – EN ISO 3506

Washer: stainless steel (A2/A4) – EN ISO 3506
with vulcanised EPDM seal

Component I: S280GD to S350GD – EN 10346
Component II: S280GD to S350GD – EN 10346

Drilling capacity: $\Sigma t_i \leq 2 \times 1.00 \text{ mm}$

Timber substructures:
No properties noted

$t_{N,II}$ [mm]	0.40	0.50	0.55	0.63	0.75	0.88	1.00
$V_{R,k}$ [kN] for $t_{N,I} =$	0.40	0.88	0.88	0.88	0.88	0.88	0.88
	0.50	0.88	1.56	1.56	1.56	1.56	1.56
	0.55	0.88	1.56	1.76	1.76	1.76	1.76
	0.63	0.88	1.56	1.76	2.09	2.09	2.09
	0.75	0.88	1.56	1.76	2.09	2.57	2.57
	0.88	0.88	1.56	1.76	2.09	2.57	3.11
	1.00	0.88	1.56	1.76	2.09	2.57	3.11
	1.13	—	—	—	—	—	—
	1.25	—	—	—	—	—	—
$N_{R,k}$ [kN] for $t_{N,I} =$	0.40	0.60	0.82	0.94	1.00	1.00	1.00
	0.50	0.60	0.82	0.94	1.14	1.44	1.67
	0.55	0.60	0.82	0.94	1.14	1.44	1.80
	0.63	0.60	0.82	0.94	1.14	1.44	1.80
	0.75	0.60	0.82	0.94	1.14	1.44	1.80
	0.88	0.60	0.82	0.94	1.14	1.44	1.80
	1.00	0.60	0.82	0.94	1.14	1.44	1.80
	1.13	—	—	—	—	—	—
	1.25	—	—	—	—	—	—
$N_{R,II,k}$ [kN] =	0.60	0.82	0.94	1.14	1.44	1.80	2.14

– If component I and II made of S320GD or S350GD all values can be increased by 8.3%.

Fastening screws JF

Self-drilling screw
JF3-(FR/LT)-2-6.0xL, JF6-(FR/LT)-2-6.0xL
 with hexagon head or round head with TX-drive system and sealing washer $\geq \text{Ø}11 \text{ mm}$

Annex 19

Materials:

Fastener: stainless steel (A2) – EN ISO 3506
stainless steel (A4) – EN ISO 3506

Washer: stainless steel (A2/A4) – EN ISO 3506
with vulcanised EPDM seal

Component I: S280GD to S350GD – EN 10346
Component II: S280GD to S350GD – EN 10346

Drilling capacity: $\Sigma t_i \leq 2 \times 1.00 \text{ mm}$

Timber substructures:
No properties noted

$t_{N,II}$ [mm]	0.40	0.50	0.55	0.63	0.75	0.88	1.00
$V_{R,k}$ [kN] for $t_{N,I} =$	0.40	0.96	0.96	0.96	0.96	0.96	0.96
	0.50	0.96	1.56	1.56	1.56	1.56	1.56
	0.55	0.96	1.56	1.76	1.76	1.76	1.76
	0.63	0.96	1.56	1.76	2.09	2.09	2.09
	0.75	0.96	1.56	1.76	2.09	2.57	2.57
	0.88	0.96	1.56	1.76	2.09	2.57	3.11
	1.00	0.96	1.56	1.76	2.09	2.57	3.61
	1.13	—	—	—	—	—	—
	1.25	—	—	—	—	—	—
$N_{R,k}$ [kN] for $t_{N,I} =$	0.40	0.60	0.82	0.94	1.14	1.44	1.46
	0.50	0.60	0.82	0.94	1.14	1.44	1.76
	0.55	0.60	0.82	0.94	1.14	1.44	1.80
	0.63	0.60	0.82	0.94	1.14	1.44	1.80
	0.75	0.60	0.82	0.94	1.14	1.44	1.80
	0.88	0.60	0.82	0.94	1.14	1.44	1.80
	1.00	0.60	0.82	0.94	1.14	1.44	1.80
	1.13	—	—	—	—	—	—
	1.25	—	—	—	—	—	—
$N_{R,II,k}$ [kN] =	0.60	0.82	0.94	1.14	1.44	1.80	2.14

– If component I and II made of S320GD or S350GD all values can be increased by 8.3%.

Fastening screws JF

Self-drilling screw
JF3-(FR/LT)-2-6.0xL, JF6-(FR/LT)-2-6.0xL
 with hexagon head or round head with TX-drive system and sealing washer $\geq \text{Ø}14 \text{ mm}$

Annex 20

Materials:

Fastener: stainless steel (A2) – EN ISO 3506
stainless steel (A4) – EN ISO 3506

Washer: stainless steel (A2/A4) – EN ISO 3506
with vulcanised EPDM seal

Component I: aluminium alloy
with $R_{m,min} = 165 \text{ N/mm}^2$ – EN 573

Component II: aluminium alloy
with $R_{m,min} = 165 \text{ N/mm}^2$ – EN 573

Drilling capacity: $\Sigma t_i \leq 2 \times 1.00 \text{ mm}$

Timber substructures:
No properties noted

$t_{N,II}$ [mm]	0.40	0.50	0.60	0.70	0.80	0.90	1.00	1.20	1.50
$V_{R,k}$ [kN] for $t_{N,I} =$	0.43	0.43	0.43	0.43	0.43	0.43	0.43	0.43	0.43
0.40	0.43	0.62	0.62	0.62	0.62	0.62	0.62	0.62	0.62
0.50	0.43	0.62	0.71	0.71	0.71	0.71	0.71	0.71	0.71
0.60	0.43	0.62	0.71	0.79	0.79	0.79	0.79	0.79	0.79
0.70	0.43	0.62	0.71	0.79	0.88	0.88	0.88	0.88	0.88
0.80	0.43	0.62	0.71	0.79	0.88	1.04	1.04	1.04	1.04
0.90	0.43	0.62	0.71	0.79	0.88	1.04	1.19	0.88	0.88
1.00	0.43	0.62	0.71	0.79	0.88	1.04	1.19	1.24	1.24
1.20	0.43	0.62	0.71	0.79	0.88	1.04	1.19	1.24	1.87
1.50	0.24	0.35	0.45	0.58	0.69	0.80	0.91	1.13	1.63

– Pull-through resistance of component I according to EN 1999-1-4 chapter 8.3.3.1 or according to the specifications of the manufacturer of the aluminium profiles, see also Annex 4.

Fastening screws JF

Self-drilling screw
JF3-(FR/LT)-2-6.0xL, JF6-(FR/LT)-2-6.0xL
 with hexagon head or round head with TX-drive system and sealing washer $\geq \text{Ø}11\text{mm}$

Annex 21

Materials:

Fastener: stainless steel (A2) – EN ISO 3506
stainless steel (A4) – EN ISO 3506

Washer: stainless steel (A2/A4) – EN ISO 3506
with vulcanised EPDM seal

Component I: aluminium alloy
with $R_{m,min} = 215 \text{ N/mm}^2$ – EN 573

Component II: aluminium alloy
with $R_{m,min} = 215 \text{ N/mm}^2$ – EN 573

Drilling capacity: $\Sigma t_i \leq 2 \times 1.00 \text{ mm}$

Timber substructures:
No properties noted

$t_{N,II}$ [mm]	0.40	0.50	0.60	0.70	0.80	0.90	1.00	1.20	1.50	
$V_{R,k}$ [kN] for $t_{N,I} =$	0.40	0.55	0.55	0.55	0.55	0.55	0.55	0.55	0.55	
	0.50	0.55	0.79	0.79	0.79	0.79	0.79	0.79	0.79	
	0.60	0.55	0.79	0.91	0.91	0.91	0.91	0.91	0.91	
	0.70	0.55	0.79	0.91	1.03	1.03	1.03	1.03	1.03	
	0.80	0.55	0.79	0.91	1.03	1.15	1.15	1.15	1.15	
	0.90	0.55	0.79	0.91	1.03	1.15	1.35	1.35	1.35	
	1.00	0.55	0.79	0.91	1.03	1.15	1.35	1.54	1.54	
	1.20	0.55	0.79	0.91	1.03	1.15	1.35	1.54	1.62	
	1.50	0.55	0.79	0.91	1.03	1.15	1.35	1.54	1.62	
$N_{R,II,k}$ [kN] =		0.31	0.46	0.60	0.75	0.89	1.04	1.18	1.47	2.12

– Pull-through resistance of component I according to EN 1999-1-4 chapter 8.3.3.1 or according to the specifications of the manufacturer of the aluminium profiles, see also Annex 4.

Fastening screws JF

Self-drilling screw
JF3-(FR/LT)-2-6.0xL, JF6-(FR/LT)-2-6.0xL
 with hexagon head or round head with TX- drive system and sealing washer $\geq \text{Ø}14 \text{ mm}$

Annex 22

Materials:

Fastener: stainless steel (A2) – EN ISO 3506
stainless steel (A4) – EN ISO 3506

Washer: stainless steel (A2/A4) – EN ISO 3506
with vulcanised EPDM seal

Component I: aluminium alloy
with $R_{m,min} = 215 \text{ N/mm}^2$ – EN 573

Component II: S280GD bis S350GD – EN 10346

Drilling capacity: $\Sigma t_i \leq 1.50 \text{ mm} + 1.00 \text{ mm}$

Timber substructures:
No properties noted

$t_{N,II}$ [mm]	0.40	0.50	0.55	0.63	0.75	0.88	1.00
$V_{R,k}$ [kN] for $t_{N,I} =$							
0.40	0.55	0.55	0.55	0.55	0.55	0.55	0.55
0.50	0.55	0.79	0.79	0.79	0.79	0.79	0.79
0.60	0.55	0.79	0.85	0.85	0.91	0.91	0.91
0.70	0.55	0.79	0.85	0.85	0.95	1.14	1.14
0.80	0.55	0.79	0.85	0.85	0.95	1.42	1.42
0.90	0.55	0.79	0.85	0.85	0.95	1.42	1.90
1.00	0.55	0.79	0.85	0.85	0.95	1.42	2.38
1.20	0.55	0.79	0.85	0.85	0.95	1.42	2.38
1.50	0.55	0.79	0.85	0.85	0.95	1.42	2.38
$N_{R,II,k}$ [kN] =	0.60	0.82	0.94	1.14	1.44	1.80	2.14

– Pull-through resistance of component I according to EN 1999-1-4 chapter 8.3.3.1 or according to the specifications of the manufacturer of the aluminium profiles, see also Annex 4.

Fastening screws JF

Self-drilling screw
JF3-(FR/LT-)2-6.0xL, JF6-(FR/LT-)2-6.0xL
 with hexagon head or round head with TX-drive system and sealing washer $\geq \text{Ø}14 \text{ mm}$

Annex 23